

**Laser solutions**  
for general marking  
applications



WE  
THINK  
LASER

## **ROFIN – Lasers for industrial material processing**

ROFIN is a global leader in developing and manufacturing of industrial lasers and laser-based products used in material processing applications. With a variety of CO<sub>2</sub>, rod, disc, fiber and diode lasers, pulsed or cw, ROFIN offers the widest and most powerful product range for industrial materials processing.

ROFIN combines the benefits of an experienced laser manufacturer with application-specific professional competence. People at ROFIN have always developed not only laser sources but also complete turn-key laser systems for most diverse applications. That means 30 years of experience – not only in building lasers – but also in application development, in laser systems manufacture and in the entire range of material processing technologies.



## **Laser marking – fast, flexible, durable**

Whether it's metal, plastics, glass, ceramics, wood or semiconductors – there are few materials that cannot be marked by laser. In a wide variety of sectors, flexible and permanent marking with lasers has become the preferred method of identifying parts. Laser marking is a fast and flexible process that can mark alphanumerics, graphics, logos, barcodes and bitmaps. Compared with other marking technologies such as inkjet printing and mechanical marking, laser marking has a number of advantages. It offers very high processing speeds, low operational costs and consistent high quality and durable results. It is a contact-free process which avoids adding any undesirable substance to the workpiece. Laser marking systems are compact and offer very high flexibility in automation.

ROFIN offers a complete product line-up, optimized for laser marking: laser sources, laser markers, all-in-one laser marking systems and customized marking solutions. In order to perfectly meet specific application requirements, laser sources are available in different power ranges and wavelengths of 1064, 532 and 355 nm. Most marking systems can be equipped with different laser sources. Superior beam quality and excellent mechanical and optical quality ensure sustained, precise marking results and reliable operation in rough industrial environments.

## All-in-one marking solutions

Class 1 laser marking stations from ROFIN are available in different sizes and designs in order to offer best solutions for individual requirements. Various options, fixed and selectable laser sources enable exact adaptation to every marking task.



**EasyMark series**

With a footprint of just 60x60 cm, the EasyMark series are one of the most compact laser marking devices on the market. Marking tasks on metallic surfaces and plastics are handled effortlessly and with perfect results. The laser marker operates with conventional household power source and does not require any external cooling.



**CombiLine Cube**

The CombiLine Cube is an innovative all-purpose laser marking station. Different laser sources, such as PowerLine E Air series, PowerLine E series or PowerLine F series, can be integrated into the laser workstation according to individual requirements.



**CombiLine Advanced**

The CombiLine Advanced offers reliable 24/7 operation, ensured through ROFIN's many years of experience in the manufacture of superior machines. The stable design of the laser workstation guarantees precise marking results. The worktable even carries large and heavy workpieces of up to 100 kg (model WT).

## Marking lasers

Each of the laser sources mentioned below offers excellent marking results on nearly all materials.



**PowerLine E Air 10 and 25**

### All air-cooled laser marker with low operating costs

The PowerLine E Air 10 is an end-pumped solid-state laser, which is completely air-cooled. The operating costs of the system are low due to reduced energy consumption. Due to its efficient cooling technology the PowerLine E Air 10 is almost maintenance-free.

As part of industrial production processes, laser marking has to deal with critical surfaces quite frequently. The PowerLine E Air 25 provides best marking results even in case of dusty, oily or oxidized parts. Besides common marking tasks the PowerLine E Air 25 is a perfect choice for engraving, as well.

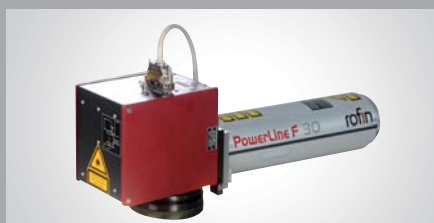

**PowerLine F 20 and 30**

### Fiber technology with compact design

The PowerLine F 20/30 is a diode-pumped, q-switched fiber laser. It excels in high diode life and requires only minimum maintenance with attractive total operating costs. The system is air-cooled and needs only 300 and 380 watts respectively.

The space-efficient design of the PowerLine F series facilitates integration into existing production environments. A flexible optical fiber connects the very compact laser head with the supply unit where the laser beam is being generated.

## EasyMark series

Most compact  
laser marking solution



Metallic surfaces and plastics, plain and curved parts, standard marking tasks or serial numbers, stationary or mobile use – the EasyMark series provide a flexible solution for moderate batch sizes. Program-controlled axes (one linear Z-axis and one rotary axis) can be easily integrated into the system for more marking freedom. The laser marker holds parts up to a size of 450 x 150 x 200 mm (W x H x D). Focusing and positioning aids ensure that the device can be easily operated. The system is available either with an actively air-cooled 10 watts laser or with a 20 watts fiber laser.

### Your benefits

- compact desktop system
- suitable for small parts
- integrated air cooling

## CombiLine Cube

Flexible and  
efficient



The CombiLine Cube has compact dimensions and offers an efficient solution for manual laser marking. All 19" components can be integrated into the support frame. The 17" TFT monitor and the keyboard are integrated in the housing. An observation window allows monitoring of the marking progress. Two different modes of access ensure easy setup process and short cycle times. For easy job setup the machine front slides up to give wide access to the marking field. During production, the fully automated pneumatic door provides for short cycle times. The marking process is easily started at the push of a button or optionally by a foot switch. Process visualization is done via the monitor, this ensuring high operation comfort. As an option, two circumferential indexers are available for marking cylindrical workpieces. A compact compressor serves for the operation of the pneumatic door.

### Your benefits

- cost-optimized, flexible solution
- short cycle times by quick job setup
- low operating costs by actively air-cooled, efficient lasers

## CombiLine Advanced

### Reliable 24/7 operation



Version with rotary table

Due to the positioning possibilities of the laser via three program-controlled axes, even parts of complex geometry can be marked easily. A rotary axis, which is required for the marking of cylindrical parts, is available optionally. The CombiLine Advanced process visualization via 15" TFT touchscreen monitor ensures maximum operating comfort. Accommodating all its supply units in a compact housing, the workstation can be set up where it ideally meets the demands for workflow and best access. To ensure optimal working height, the CombiLine Advanced is available for seated or standing operation.

#### Your benefits

- suitable for complex geometry and heavy workpieces
- worktable and rotary table versions available
- selectable laser source



Marking of small-size batches



Marking of middle-size batches



Marking of heavy parts at high flexibility

WE  
THINK  
LASER

## PowerLine E Air 10 and 25

### Completely air-cooled laser markers



Each component of the PowerLine E Air 10 /25 laser markers work with efficient air-cooling. The operating costs of the system are low due to reduced energy consumption and use of advanced air-cooled technology. In order to perfectly meet specific application requirements, the laser markers of the PowerLine E Air series are available in two different power ranges. They mark different materials with alphanumerics, graphics, grayscale pictures, barcodes and matrix codes with high quality and within a short cycle time. In order to offer best marking results on certain metals and plastics, the Power Line E series are also available with water-air cooling with wavelengths of 1064 nm, 532 nm and 355 nm. Double head configurations with beam splitter and beam switch offer benefits when it comes to large marks or need for short process times. The PC (2 rack units) and the supply module (3 rack units) of the laser marker PowerLine E Air series are housed in standard 19" modules. The compact laser head has a length of 500 mm and can be integrated together with the supply and control components in customer-specific or ROFIN-supplied laser workstations.

#### Your benefits

- low operating costs due to air cooling technology
- 19" components, compact dimensions
- different power ranges

## PowerLine F 20 and 30

### Fiber laser for a wide range of marking applications



The PowerLine F 20/30 is a diode-pumped q-switched fiber laser offering different output powers and specially optimized for marking applications. Nearly all metals and plastics can be economically processed with this laser sources. The space-efficient design of the PowerLine F 20/30 facilitates integration into existing production environments. A flexible optical fiber connects the very compact laser head with the supply unit where the laser beam is being generated. The diode-pumped laser source excels in high diode life and allows efficient operation with minimum maintenance and with reduced total operating costs. This system is air-cooled and needs only 300 and 380 watts respectively.

#### Your benefits

- efficient operation with minimum maintenance
- low operating costs with only 300 and 380 watts power consumption respectively
- extremely compact design for easy integration



Marking of small characters



Marking of plastics



Marking of machine-readable codes

WE  
THINK  
LASER

## Application knowledge

ROFIN offers you a comprehensively equipped laser application lab. Customer applications and lab studies can be carried out with the assistance of our experienced engineers. Practically all of our marking systems are available for application trials.

You specify your characteristic application data, the material to be processed, the desired marking geometry and constraints of your process environment. We will present you all possible laser concepts for consideration, with benefits and implications and together we will find the perfect solution for your individual laser task.



Lab studies by experienced engineers

If your application strikes a new path in laser marking, we can call on our wide range of high-performance laser sources and combine them with efficient engineering and process technology to create a tailor-made complete system solution. We are glad to welcome customers to join us for application tests in order to achieve best results.



Personalization

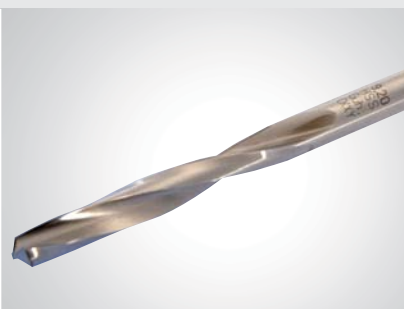

Annealing



Identification



Tracability



Machine readable codes



Deep engraving



Circular marking

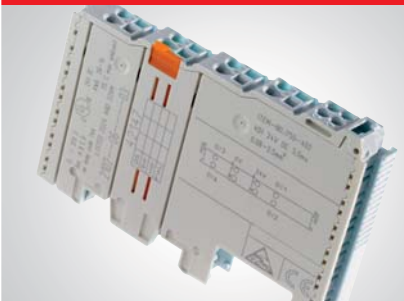

Color change



Just-in-time marking

## VisualLaserMarker software – powerful and simple to use

VisualLaserMarker (VLM) is a sophisticated and flexible marking software used for all Rofin lasers. Running on a standard PC environment, layout and transfer of the marking contents is a breeze. VLM is a “what you see is what you get” type software and offers the flexibility to be simple to use and yet powerful. VLM is able to fully integrate into any production software and is configured to handle all common communication methods. True type fonts are used directly, no need to convert to special fonts. VLM offers a wide range of marking functions, fonts and predefined laser parameter sets. The user-interface is clearly arranged and can be operated easily, which reflects ROFINs longtime laser marking expertise.

Laser display, graphical user interface for the operator.



Laser workstation oriented visualization via web interface.

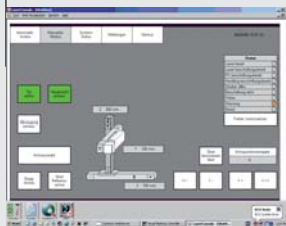

Row and column marking of workpieces.

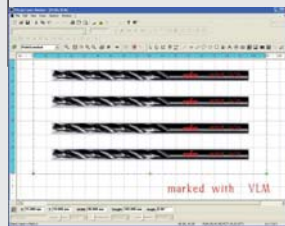

VLM handles a wide variety of marking content e.g. matrix-codes, barcodes and serial numbers. Extremely small marks can be realized depending on the material. The sophisticated software controls marking on flat and curved surfaces and even marking-on-the-fly applications. Via an optical fast focussing module various workpiece heights can be processed quickly – travel time between the upper and the lower maximum positions is just 15 ms.



A competent, strong software team with solid knowledge ensures excellent software quality harmonized with the customer requirements. Continuous, user-oriented development, individual solutions and customer support are the focus of software work.

## Service and training

Modern industrial laser marking equipment requires a qualified knowledge of laser technology and of its applications. At the ROFIN Laser Marking Seminar Center, we can offer you a choice of various training programs. With our operation, maintenance, and programming courses we provide the qualified training necessary to meet these demands.

ROFIN optimized the design of its marking lasers for easy servicing. Maintenance work is reduced to a minimum. Just in case: ROFIN's worldwide service network is ready for support on-site when required.



We offer local spare parts centers with modern logistics. Our customers all over the world benefit from individual service agreements and hotline support.

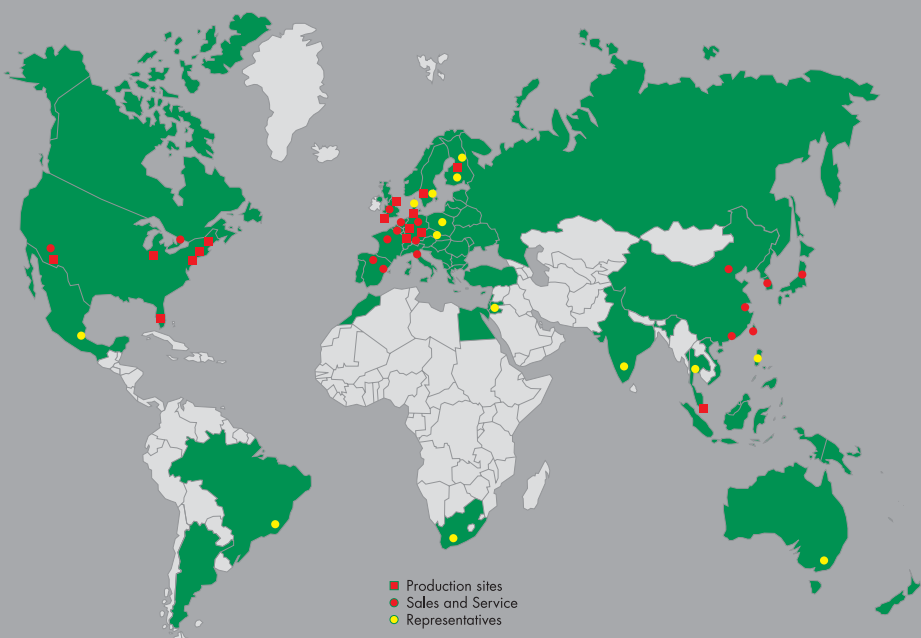

## EasyMark series

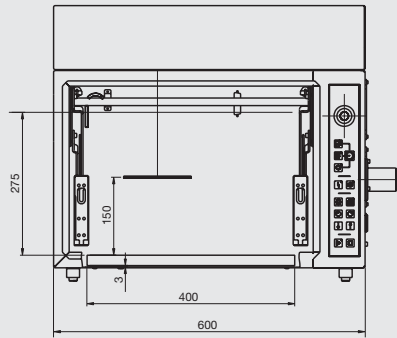

Front view

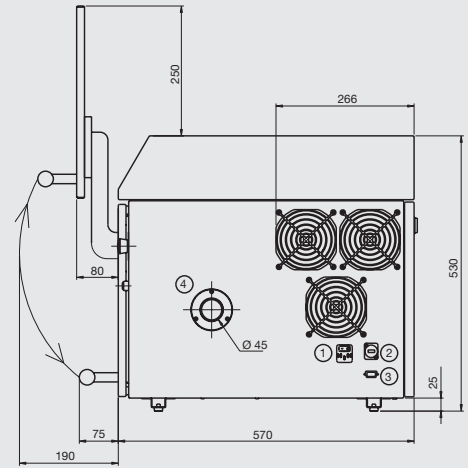

Side view

### EasyMark / F 20

Laser power class (W):	10, 20
Pulse frequency (kHz):	programmable, 0 - 150

### Supply and marking unit

Dimensions (W x D x H, mm):	600 x 645 x 530
Machine weight (kg):	85
Max. workpiece dimension (W x D x H, mm):	450 x 200 x 150
Max. workpiece weight incl. fixture (kg):	10
Marking field size (mm):	120 x 120
Z-axis travel (mm):	120
Door:	manual
Power supply:	100 - 240 VAC +/-10%, 50/60 Hz
Max. power consumption (W):	410
Cooling:	integrated air cooling
Environment temperature (°C):	15 - 35
Focal distance (mm):	160
Color:	RAL 7016, RAL 9002

### Options

z-axis  
circumferencial indexer  
extraction unit

## CombiLine Cube

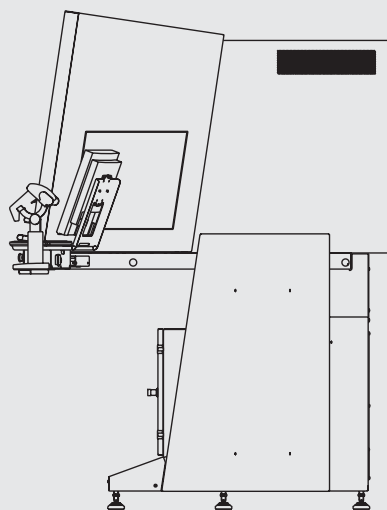

Side view

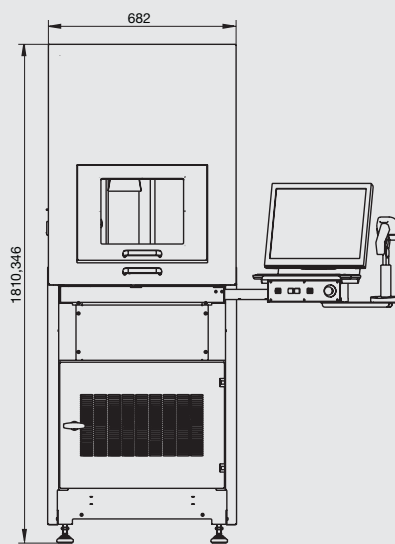

Front view

### CombiLine Cube

Marking laser:	PowerLine E Air 10/25, PowerLine E 20/25, PowerLine E 20 SHG, PowerLine E 20 THG, PowerLine F 20/30
Dimensions (W x D x H, mm):	1182 x 1380 x 1810 (closed), with open hood H = 2285
Machine weight (kg):	depending on laser system max. 450
Max. workpiece dimension (W x D x H, mm):	ca. 350 x 350 x 350 (height depends on optics) max. 500 x 375 x 300 for loading via open service door
Max. workpiece weight incl. fixture (kg):	20
Marking field size (mm):	120 x 120, (f = 160 standard)
Z-axis travel (mm):	Max. 300, depending on optics and laser system
Door:	fully automated
Lateral feeding of the workpiece:	customized solution
Power supply:	PowerLine F 20/30: 100 - 240 VAC +/- 10 %, 50/60 Hz PowerLine E Air 10: 120 - 240 VAC, 50/60 Hz PowerLine E Air 25: 230 VAC, 50/60 Hz PowerLine E 20/25: 230 +/-10% VAC, 50/60 Hz PowerLine E 20 SHG/THG: 230 VAC +/-10%, 50/60 Hz
Max. power consumption (W):	400 (depending on configuration)
Compressed air (bar):	6 - 10 optionally: compressor

### Options

circumferential indexer  
compressor (if no pneumatic supply)  
foot switch  
extraction unit completely controlled by system interface  
barcode scanner with carrier integrated in support frame

## CombiLine Advanced

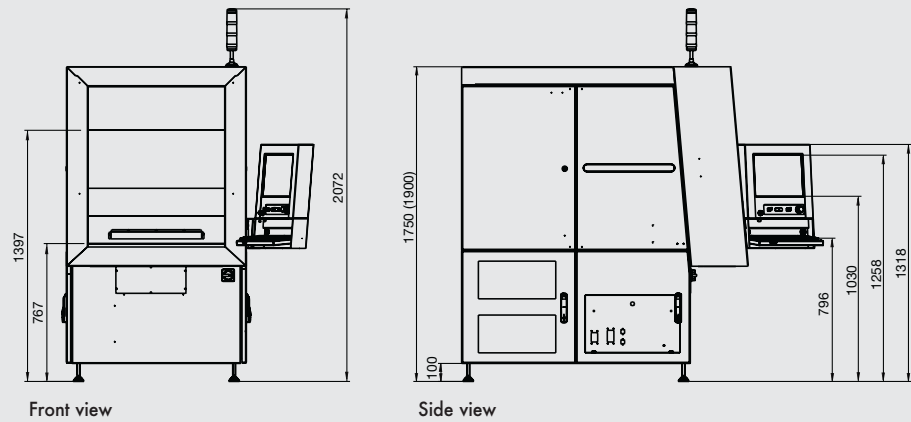

	CombiLine Advanced WT	CombiLine Advanced RT
Marking laser:	PowerLine E Air 10/25 PowerLine E 20/25 PowerLine E 40 PowerLine E 20/25 SHG PowerLine E 20 THG PowerLine F 20/30	PowerLine E Air 10/25 PowerLine E 20/25 PowerLine E 40 PowerLine E 20/25 SHG PowerLine E 20 THG PowerLine F 20/30
Dimensions: (W x D x H, mm)	1376 x 2013 x 1750 (seated operation) 1376 x 2013 x 1900 (standing operation)	1376 x 2013 x 1750 (seated operation) 1376 x 2013 x 1900 (standing operation)
Machine weight (kg):	420	490
Max. workpiece dimension: (W x D x H, mm)	760 x 600 x 500 (WT)	400 x 300 x 295 (RT)
Max. workpiece weight incl. fixture (kg):	100	10 each side
Working height (mm):	750 (standing operation: 900)	750 (standing operation: 900)
Marking field size (mm):	120 x 120	180 x 180
Axis travel (mm):	z: 300	z: 300
Rotary table diameter (mm):	not applicable	800
Rotation time of rotary table (s):	not applicable	1.2
Door:	pneumatic door	fully automatic
Power supply:	230 / 400 V (+/- 10%); 3P; N; PE; 50/60 Hz;	230 / 400 V (+/- 10%); 3P; N; PE; 50/60 Hz;
Max. power consumption (kW):	approx. 4 kW (at 50/60 Hz)	approx. 4 kW (at 50/60 Hz)
Compressed air (bar):	6	not applicable
Color:	RAL 7016, RAL 9002	RAL 7016, RAL 9002

### Options

x-axis:	yes	yes
y-axis:	yes	not applicable
circumferencial indexer:	yes	yes
extraction unit:	yes	yes
foot switch:	yes	yes

## Laser workstation comparison at a glance

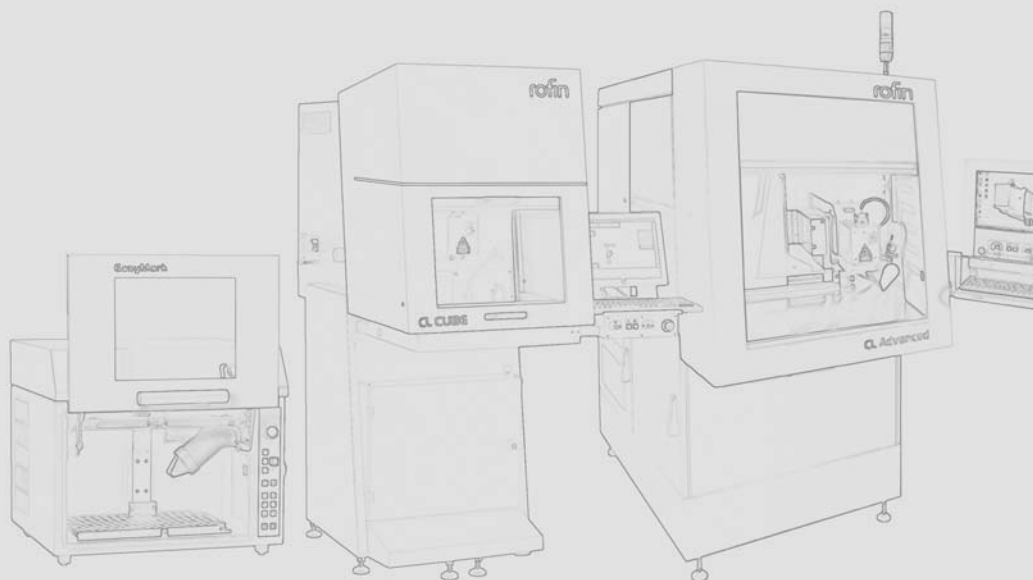

	<b>EasyMark series</b>	<b>CombiLine Cube</b>	<b>CombiLine Advanced</b>
Marking laser:	fixed, 10 watts air-cooled, 20 watts fiber	PowerLine E Air 10/25 PowerLine E 20/25 PowerLine E 20 SHG PowerLine E 20 THG PowerLine F 20/30	PowerLine E Air 10/25 PowerLine E 20/25, PowerLine E 40 PowerLine E 20/25 SHG PowerLine E 20 THG PowerLine F 20/30
Dimensions (W x D x H, mm):	600 x 645 x 530	1182 x 1380 x 1810 (closed), with open hood H = 2285	1376 x 2013 x 1750 (seated operation) 1376 x 2013 x 1900 (standing operation)
Machine weight (kg):	85	depending on laser system max. 450	420 (WT), 490 (RT)
Max. workpiece dimension: (W x D x H, mm)	450 x 200 x 150	ca. 350 x 350 x 350 (height depends on optics) max. 500 x 375 x 300 when loading via open service door	760 x 600 x 500 (WT) 400 x 300 x 295 (RT)
Max. workpiece weight incl. fixture (kg)	10	20	100 (WT) 10 each side (RT)
Marking field size (mm):	120 x 120	120 x 120 (f = 160 standard)	120 x 120 (WT) 180 x 180 (RT)
Axis travel (mm):	120,	z: max. 300, depending on optics and laser system	z: 300 (WT/RT)
Door:	manual	fully automated	fully automated pneumatic door (WT)
<b>Options</b>			
x-axis:	not applicable	not applicable	yes
z-axis:	yes	yes	standard
y-axis:	not applicable	not applicable	yes (WT)
circumferential indexer:	yes	yes	yes
extraction unit:	yes	yes	yes
foot switch:	not applicable	yes	yes
barcodescanner integrated in support frame	not applicable	yes	not applicable

## PowerLine E Air 10 and 25

### Laser and galvo PowerLine E Air 10

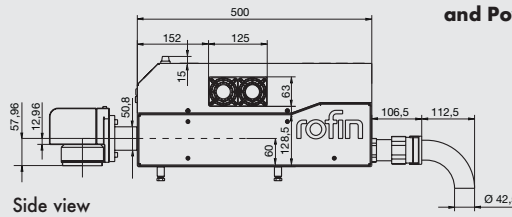

### Laser and galvo PowerLine E Air 25

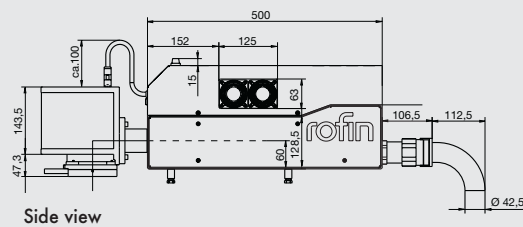

### Supply unit for PowerLine E Air 10/25 and PowerLine F 20/30

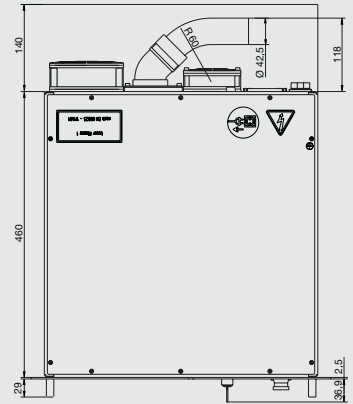

Top view

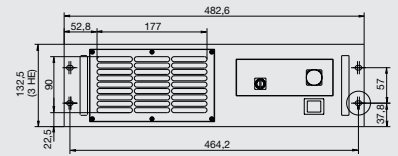

Front view

### Laser head

Wavelength (nm):	1064
Pulse frequency (kHz):	1 - 200, cw as well
Laser dimensions (L x W x H, mm):	500 x 118 x 220
Laser weight (kg):	approx. 16
Ingress protection:	IP 54
Air flow (m <sup>3</sup> /h):	approx. 120

### Marking unit

Field size (mm):	120 x 120 (other size on request)
Focal distance (mm):	160 (other focal distance on request)
Galvo dimensions (L x W x H, mm):	PowerLine E Air 10: 100 x 77 x 77.5 PowerLine E Air 25: 167 x 118 x 200
Galvo weight (kg):	PowerLine E Air 10: approx. 1.5 PowerLine E Air 25: approx. 2.7
Ingress protection:	IP 54

### Supply unit and PC (19")

Supply unit dimensions (mm):	460 x 483 (19") x 3 rack units
Supply unit weight (kg):	25
PC dimensions (mm):	460 x 483 (19") x 2 rack units
PC weight (kg):	10
Software:	Windows XP embedded, DVD RW, USB 2.0, LAN
Cooling:	integrated air cooling
Power supply:	100 - 264 V AC, 50 - 60 Hz (PowerLine E Air 10) 180 - 264 V AC, 50 - 60 Hz (PowerLine E Air 25)
Power consumption supply unit (W):	500 (PowerLine E Air 10) 610 (PowerLine E Air 25)
Ingress protection:	IP 20
Operating temperature (°C):	15 - 35
Air flow 19" supply unit (m <sup>3</sup> /h):	approx. 250
Air flow 19" PC (m <sup>3</sup> /h):	approx. 80

## PowerLine F 20 and 30

### PC for PowerLine E Air 10/25 and PowerLine F 20/30

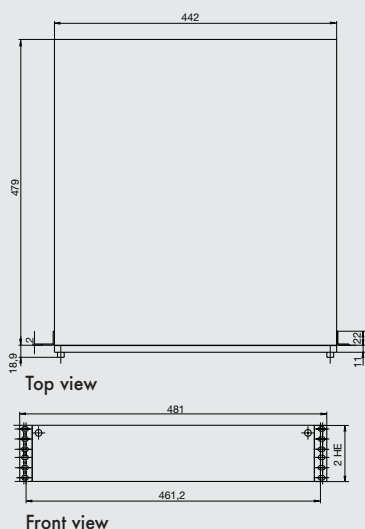

### Laser and galvo PowerLine F 20

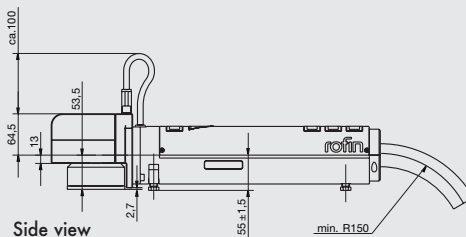

### Laser and galvo PowerLine F 30

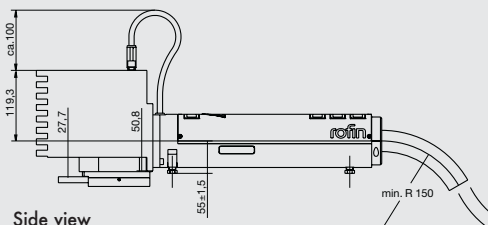

#### Laser head

Wavelength (nm):	1065 +/- 5
Pulse frequency (kHz):	PowerLine F 20: 20 - 100 PowerLine F 30: 30 - 100
Laser dimensions (mm):	length 380, Ø 90
Laser weight (kg):	5
Ingress protection:	IP 54

#### Marking unit

Field size (mm):	120 x 120
Focal distance (mm):	160 (other focal distance on request)
Galvo dimensions (L x W x H, mm):	PowerLine F 20: 100 x 77 x 77.5 PowerLine F 30: 167 x 118 x 200 (F 30)
Galvo weight (kg):	PowerLine F 20: approx. 1.5 PowerLine F 30: approx. 2.7
Ingress protection:	IP 54

#### Supply unit and PC (19")

Supply unit dimensions (mm):	460 x 483 (19") x 3 rack units
Supply unit weight (kg):	20
PC dimensions (mm):	460 x 483 (19") x 2 rack units
PC weight (kg):	10
Software:	Windows XP embedded, DVD RW, USB 2.0, LAN
Power supply:	100 - 240 VAC, 50/60 Hz
Power consumption supply unit (W):	PowerLine F 20: approx. 300 PowerLine F 30: approx. 380
Ingress protection:	IP 20
Operating temperature (°C):	15 - 35
Air flow 19" supply unit (m³/h):	approx. 250
Air flow 19" PC (m³/h):	approx. 80

## Laser comparison at a glance

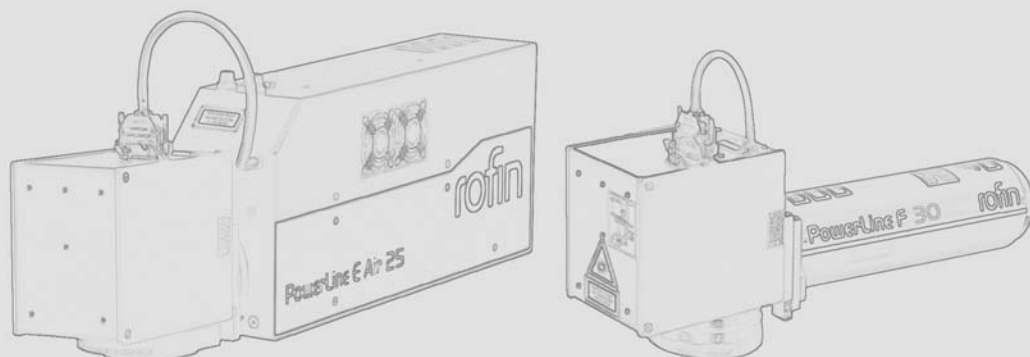

	<b>PowerLine E Air 10</b>	<b>PowerLine E Air 25</b>	<b>PowerLine F 20/30</b>
Wavelength (nm):	1064	1064	1065 +/- 5
Cooling:	completely air-cooled	completely air-cooled	completely air-cooled
Power class (W):	up to 10	up to 25	up to 30
Pulse frequency (kHz):	1 - 200, cw as well	1 - 200, cw as well	20 - 100 (F 20) 30 - 100 (F 30)
Laser dimensions (L x W x H, mm):	500 x 118 x 220	500 x 118 x 220	380, Ø 90
Laser weight (kg):	approx. 16	approx. 16	5
Galvo dimensions (L x W x H, mm):	100 x 77 x 77.5	167 x 118 x 200	100 x 77 x 77.5 (F 20) 167 x 118 x 200 (F 30)
Galvo weight (kg):	approx. 1.5	approx. 2.7	approx. 1.5 (F 20) approx. 2.7 (F 30)
Standard marking field size (mm): (other sizes on request)	120 x 120	120 x 120	120 x 120
Supply unit dimensions (mm):	460 x 483 (19") x 3 rack units	460 x 483 (19") x 3 rack units	460 x 483 (19") x 3 rack units
Supply unit weight (kg):	25	25	20
PC dimensions (mm):	460 x 483 (19") x 2 rack units	460 x 483 (19") x 2 rack units	460 x 483 (19") x 2 rack units
PC weight (kg):	10	10	10
Software:	Windows XP embedded, DVD RW, USB 2.0, LAN	Windows XP embedded, DVD RW, USB 2.0, LAN	Windows XP embedded, DVD RW, USB 2.0, LAN
Power supply:	100 - 264 V AC, 50 - 60 Hz	180 - 264 V AC, 50 - 60 Hz	100 - 240 V AC, 50 - 60 Hz
Power consumption supply unit (W):	500	610	300 (F 20), 380 (F 30)
Operating temperature (°C):	15 - 35	15 - 35	15 - 35

## ROFIN Sales & Service

### ROFIN-BAASEL Benelux B.V.

Brussels Office  
Rue Abbé Cuypers, 3  
1040 Brussels, Belgium  
Tel.: +32-(0)-2-7412-427  
Fax: +32-(0)-2-7412-404  
info@rofin-baasel.nl

### ROFIN-BAASEL, Inc.

Tempe Office  
1565 W. University Drive, Suite 101  
Tempe, AZ 85281, USA  
Tel.: +1-480-777-1199  
Fax: +1-480-517-9684  
info@rofin-baasel.com

### ROFIN-BAASEL España, S.L.S. UNIP.

Barcelona Office  
Plaza María Aurelia Capmany, 1-A  
08970 Sant Joan Despí, Barcelona, Spain  
Tel.: +34-93-4770-644  
Fax: +34-93-4770-865  
info@rofin-es.com

### ROFIN-BAASEL China Co., Ltd

Shenzhen Office  
Room 368, Floor 3  
Hua Yu Hotel, Industry West Rd.  
Longhua Town  
Baoan District, Shenzhen  
P.R. China (518109)  
Tel.: +86-(0)755-2814-5769  
Fax: +86-(0)755-2814-5730  
info@rofin-baasel.com.cn

### ROFIN-BAASEL France S.A.

Sartrouville Office  
7, Rue d'Estienne d'Orves  
78500 Sartrouville Cedex, France  
Tel.: +33-(0)-1-395-77133  
Fax: +33-(0)-1-395-76577  
info-marquage@rofin.fr

### ROFIN-BAASEL China Co., Ltd

Beijing Office  
F8D6, Tower 1, Xihuan Plaza  
No. 1 Xizhimenwai Street, Xicheng District  
Beijing 100044  
Tel.: +86-10-58302990  
Fax: +86-10-58302968  
info@rofin-baasel.com.cn

## ROFIN Subsidiaries & Production Sites

### HEADQUARTERS LASER MACRO

ROFIN-SINAR Laser GmbH  
Berzeliusstr. 87  
22113 Hamburg, Germany  
Tel.: +49-(0)40-73363-0  
Fax: +49-(0)40-73363-4100  
info@rofin-ham.de

### ROFIN-BAASEL, Inc.

68 Barnum Road,  
Devens, MA 01434-3508, USA  
Tel.: +1-978-635-9100  
Fax: +1-978-635-9199  
info@rofin-baasel.com

### ROFIN-BAASEL France S.A.

10, Allée du Cantal  
Z.I. La Petite Montagne Sud  
91018 Evry Cedex, France  
Tel.: +33-(0)1-6911-3636  
Fax: +33-(0)1-6911-3639  
info@rofin.fr

### ROFIN-BAASEL Swiss AG

Zürichstraße 23  
2504 Biel, Swiss  
Tel.: +41-(0)32-322-1010  
Fax: +41-(0)32-342-2662  
info@rofin-baasel.ch

### ROFIN-BAASEL Singapore Pte. Ltd.

Block 5012, Ang Mo Kio Avenue 5  
#04-05 TECHplace II  
Singapore 569876  
Tel.: +65-6482-1091  
Fax: +65-6482-1158  
reception@rofin-baasel.com.sg

### ROFIN-BAASEL Canada Ltd.

3600A Laird Road Unit 15  
Mississauga, ON CANADA L5L 6A6  
Tel.: +1-905-607-0400  
Fax: +1-905-607-0655  
info-canada@rofin-inc.com

### HEADQUARTERS LASER MICRO

Carl Baasel Lasertechnik GmbH & Co. KG  
Petersbrunner Str. 1b  
82319 Starnberg, Germany  
Tel.: +49-(0)8151-776-0  
Fax: +49-(0)8151-776-4159  
sales@baasel.de

### ROFIN-BAASEL Italiana S.r.l.

Viale Lombardia, 159  
20052 Monza (MI), Italy  
Tel.: +39-039-2729-1  
Fax: +39-039-2141 304  
info@rofin.it

### ROFIN-BAASEL China Co., Ltd.

Room 206, Bldg 2.  
No. 1077 ZuChongzhi Road  
Shanghai 201203, P.R.China  
Tel.: +86-21-685522-16  
Fax: +86-21-50273793  
info@rofin-baasel.com.cn

### ROFIN-BAASEL Taiwan Ltd.

3F, #33, Lane 66, Rueiguang Road  
Neihu Taipei City 114, Taiwan  
Tel.: +886-2-2790-1300  
Fax: +886-2-2795-3021  
info@rofin-baasel.com.tw

### ROFIN-BAASEL Benelux B.V.

Edisonweg 52  
2952 AD Alblisserdam, Netherlands  
Tel.: +31-(0)78-69310-37  
Fax: +31-(0)78-69310-79  
info@rofin-baasel.nl

### ROFIN-SINAR UK Ltd.

York Way, Willerby,  
Kingston upon Hull  
HU10 6HD, United Kingdom  
Tel.: +44-(0)1482-6500-88  
Fax: +44-(0)1482-6500-22  
info@rofin-uk.com

### HEADQUARTERS LASER MARKING

ROFIN-SINAR Laser GmbH  
Dieselstr. 15  
85232 Bergkirchen, Germany  
Tel.: +49-(0)8131-704-0  
Fax: +49-(0)8131-704-4100  
info@rofin-muc.de

### ROFIN-BAASEL Japan Corp.

1042-4 Toda, Atsugi-shi  
Kanagawa-ken, Japan 243-0023  
Tel.: +81-(0)46-229-8655  
Fax: +81-(0)46-229-8541  
info@rofin-baasel.co.jp

### ROFIN-SINAR, Inc.

40984 Concept Drive  
Plymouth, MI 48170, USA  
Tel.: +1-734-455-5400  
Fax: +1-734-455-2741  
info@rofin-inc.com

### ROFIN-BAASEL España, S.L.

Pol. Arazuri-Orcayen, Calle C-12  
31170 Arazuri, Navarra, Spain  
Tel.: +34-948-324-600  
Fax: +34-948-324-605  
info@rofin-es.com

### ROFIN-BAASEL UK Ltd.

Sopwith Way  
Drayton Fields Industrial Estate  
Daventry NN11 8PB  
Northants, United Kingdom  
Tel.: +44 (0)1327-701-100  
Fax: +44 (0)1327-701-110  
sales@rofin-baasel.co.uk

### ROFIN-BAASEL Korea Co., Ltd.

#718, Daerung Technotown 12  
327-32 Gasan-Dong Gumchun-Gu  
Seoul 153-802, South Korea  
Tel.: +82-(0)2-837-1750  
Fax: +82-(0)2-837-1751  
info@rofin-baasel.co.kr

ROFIN-SINAR Laser GmbH  
Dieselstr. 15  
85232 Bergkirchen/Günding  
Tel: +49(0)8131-704-0  
Fax: +49(0)8131-704-4100  
email: info@rofin-muc.de

MARKING

Carl Baasel Lasertechnik GmbH & Co. KG  
Petersbrunner Str. 1b  
82319 Starnberg  
Tel: +49(0)8151-776-0  
Fax: +49(0)8151-776-4159  
email: info@baasel.de

MICRO

ROFIN-SINAR Laser GmbH  
Berzeliusstr. 87  
22113 Hamburg  
Tel: +49(0)40-733 63-0  
Fax: +49(0)40-733 63-4100  
email: info@rofin-ham.de

MACRO